

## OptiCop Converger<sup>®</sup> : A-Series

### BENEFITS

- Load balancing to overcome tool limitations
- VPI/VCI aggregation and IMA support
- Interface conversions to leverage existing and next generation tools
- Multi-layer filtering to access only data of interest
- Remote monitoring and tool sharing to reduce CAPEX

### OVERVIEW

NetQuest's A-Series OptiCop Converger products provide test and monitoring access for today's high-speed Asynchronous Transfer Mode (ATM) networks in Carrier, Government, and Enterprise applications. The non-intrusive access optimizes tool port usage and enables network operators to implement management and assurance strategies related to the overall performance of the services being delivered, without degrading the service or distorting the results.

ATM transport networks and their inherent quality of service play an important role in today's multi-service networks. As networks continue to converge and traffic migrates from cell to packet, the monitoring of ATM backbones used in conjunction with IP and TDM infrastructure presents a unique set of challenges. Features like circuit emulation and Inverse Multiplexing over ATM (IMA) make monitoring expensive and, in some cases, impossible since ATM support is often not available in next generation monitoring solutions. OptiCop Converger's ability to terminate and convert ATM cell traffic combined with its advanced Hybrid Inspection Technology (HIT) provide a means to extract the traffic of interest and leverage existing investments in test and monitoring tools.

### APPLICATIONS AND FEATURES

With OptiCop Converger deployed in an ATM network, engineers can traffic manage virtual circuits and paths or application protocols of interest to the appropriate test and monitor tools. Everyday, network engineers

are challenged with tool constraints like port and processing limitations, interface incompatibilities, protocol-specific testing, remote monitoring, and budget. Features like IMA traffic aggregation, multi-casting, load balancing, filtering, and routing of IP and non-IP traffic make OptiCop Converger a powerful tool in the engineering of today's advanced networks.

By providing network interface conversions to GigE monitoring tools such as Sniffers, Performance Management Probes, Lawful Intercept Systems, Security/NAC Devices, Traffic Analyzers, and Bulk Data Recorders, OptiCop Converger provides real-time access to ATM network traffic. The ATM cell traffic can be translated into standard or proprietary Gigabit Ethernet traffic at full line rate without loss of data. OptiCop Converger's flexible interfaces, unique traffic handling capabilities, high port density, and powerful parallel processing functions set a new standard for monitoring access to converged network tools.

### MONITORING ACCESS

The A-Series OptiCop Converger systems can be configured to meet the most demanding applications, with the ability to monitor SONET/SDH and PDH ATM circuits ranging from T1/E1 to OC3/STM-1 through OC12/STM-4. Inverse multiplexing is also supported on either 256 discrete T1/E1 interfaces or on up to

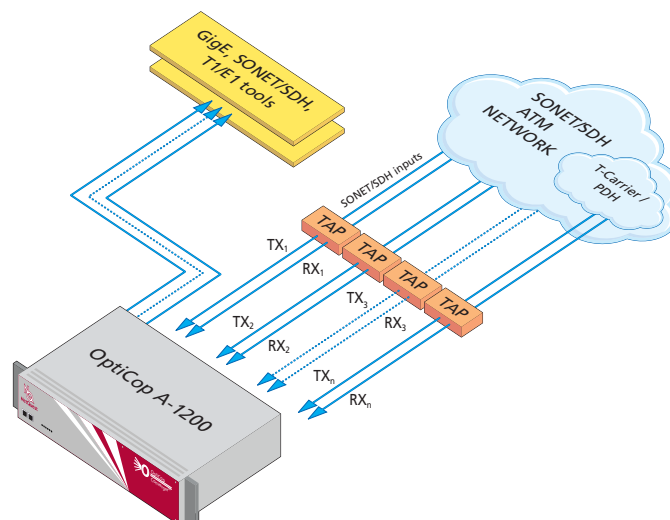

The A-1200 OptiCop Converger in a SONET/SDH ATM network

512 T1/E1 circuits embedded within SONET/SDH pipes. With up to 24 SONET/SDH network/tool interfaces, the A-Series OptiCop Converger can monitor multiple broadband circuits in either half or full duplex scenarios and will operate in conjunction with Automatic Protection Switching, ensuring monitoring applications always have the access they need.

## HYBRID INSPECTION TECHNOLOGY (HIT)

NetQuest has developed a powerful method to inspect traffic at line rate using its unique Hybrid Inspection Technology (HIT). HIT logic is based on highly parallel, pipelined hardware architecture with protocol-specific inspection algorithms defined by software and executed in specialized hardware. HIT is equally effective in processing high-speed concatenated ATM-based SONET/SDH traffic streams as it is in handling embedded low order SONET/SDH streams.

## FILTERING AND ROUTING

The OptiCop Converger leverages HIT technology by enabling the inspected data to be filtered and or routed based on user definable parameters. By filtering traffic, only the data of interest will be presented to the monitor system for processing, ensuring valuable processing resources are preserved.

Routing of the data puts the user in control of which tool interface will receive the data, and enables network, protocol, and application partitioning to match monitoring tool requirements and limitations.

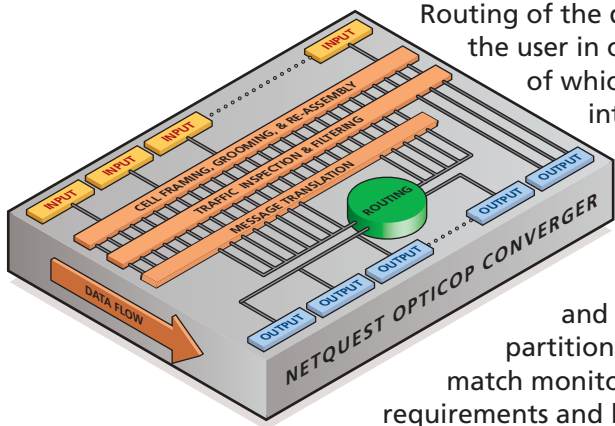

## CONFIGURATIONS

The A-Series OptiCop Converger is available in two models, the A-1200 and the A-2400, supporting 12 and 24 optical/copper interfaces respectively. Optional

support for up to 256 discrete T1/E1 interfaces is offered on the A-1200. Both models are available with either a fixed relationship between network inputs and tool outputs or with optional traffic routing, where the input to output relationship becomes a user defined logical path. The A-Series packaging is a 2RU chassis that is rack mountable and may be ordered with single or redundant power supplies with independent inputs for AC or DC sources. The table below illustrates example port configurations available. (Note: In certain input to output aggregation configurations, traffic inspection and filtering are required to prevent oversubscription)

	MODELS	
	A-1200	A-2400
Total # SFPs (inputs + outputs)	12	24
Max # OC3/STM-1 input ports	8	16
Max # OC12/STM-4 input ports	2	4
Max # GigE output ports	8	16
Max # T1/E1 input/output ports	256	-

## MANAGEMENT

The OptiCop Converger can be managed locally or remotely using menu-driven screens via Telnet or a serial crafts person port. Both interfaces provide secure access through a multi-level password protection system. OptiCop Converger has an integral SNMP V1-V3 agent that supports GET, SET, and TRAP functionality. NetQuest's proprietary UDP-based control protocol, GSCP, provides for integration of the OptiCop Converger interface into existing management systems.

For more detailed technical specifications, please email NetQuest at [info@netquestcorp.com](mailto:info@netquestcorp.com)

TECHNICAL SPECIFICATIONS	
Size	2U rack mount or table top chassis: 3.5" H x 19" W x 17.25" D (8.9cm H x 48.3cm W x 43.8cm D)
Weight	16 pounds (7.27kg)
Power	140 W (110/220 VAC or 48 VDC)
Operating Temp	32° - 122° F ( 0° - 50° C)
Humidity	10-90% non-condensing
Compliance	FCC, UL, CE, RoHS
Management	Telnet, EIA232 Craft, SNMP V1-V3

NetQuest Corporation • 523 Fellowship Road • Mount Laurel, NJ 08054 USA • +1.856.866.0505 • Fax: +1.856.866.2852 • Email: [info@NetQuestCorp.com](mailto:info@NetQuestCorp.com)

NetQuest Corporation designs, manufactures and markets innovative monitoring access products for applications in telecommunications service provider, government, and enterprise networks. Founded in 1987 and based in Mount Laurel, New Jersey, NetQuest is privately held and operates under the original management team. With more than a 20 year track record of providing cutting edge monitoring access solutions, NetQuest has developed a global customer base, marketing directly and through a network of value added resellers and representatives.