

Blade Family - OptiCop 10G

OVERVIEW

The OptiCop 10G is a 6U cPCI board level building block for cPCI system developers of network monitoring appliances. This universal high-speed networking module is designed for network access, monitoring, inspection, and surveillance applications in both WAN and LAN networks. OptiCop 10G may be used in stand-alone embedded single board appliances or as a blade in standard cPCI systems. High density, non-intrusive access combined with NetQuest's Hybrid Inspection Technology (HIT) guarantee predictable performance, keeping throughput and latency constant under any traffic load or user-defined filtering rule.

BENEFITS

- Non-intrusive access and optimization for monitoring applications
- Application support for IP, POS, ATM, and TDM networks including translations from Legacy to IP
- Access to Ethernet and SONET/SDH networks at rates of 155/622/1000/2500Mbps and 10Gbps
- Highly flexible system architecture powered by FPGA logic
- Accelerated time to market through easy integration into existing systems

SYSTEM INTEGRATION

The OptiCop 10G can accelerate development time and expand the addressable market opportunities for system developers, enabling R&D resources to focus on application layer functionality. A single integration effort of the OptiCop 10G cPCI provides non-intrusive monitor connectivity to a wide variety of networks by utilizing reconfigurable FPGA technology to define the universal SFP ports.

Management integration can be streamlined as well. OptiCop 10G can be managed by the appliance host controller using the management provisions defined by PICMIG 2.0 standards or via NetQuest's proprietary UDP-based control protocol, GSCP.

APPLICATIONS

OptiCop 10G is suitable for applications in Performance Monitoring, Service Assurance, Revenue Assurance, Lawful Interception, Network Security, Fraud Detection, and Forensics. The flexible technology allows for countless applications including:

- Inspection and interception of streams and messages on all protocol layers and routing of selected traffic to one or more 10GigE, GigE, or SONET/SDH outputs
- Switching, grooming, and broadcasting of SONET/SDH virtual tributaries down to T-carrier, PDH, and DS0/E0 streams
- Time-stamping, modifying, tagging, reformatting, and routing of Ethernet or SONET/SDH packets based on user criteria
- Monitoring and reporting of the WAN or LAN alarms and collection of traffic statistics on physical, link, network, and application layers
- Selective capture and forwarding of WAN or LAN traffic streams or packets

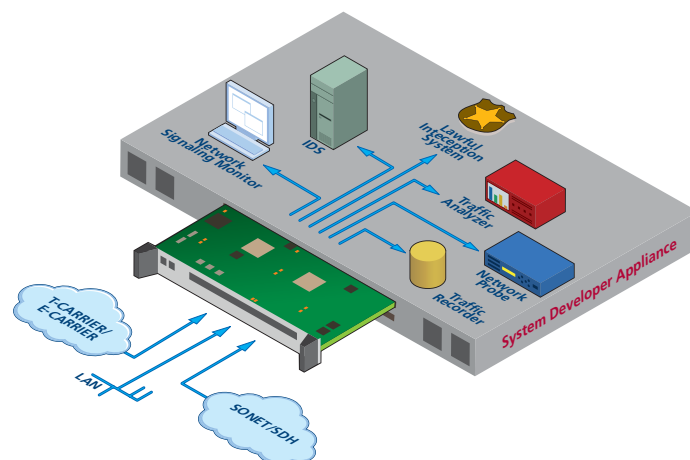

Integration of the OptiCop 10G into any cPCI-based appliance provides high-density multi-gigabit network access and optimization

NETWORK PORTS

The OptiCop 10G is equipped with 4 universal XFP ports and 4 universal SFP ports that function as monitor inputs or tool outputs. The XFP ports are user definable to support either OC192/STM-64 or 10GigE. The SFP ports are user definable to support 1 Gigabit Ethernet and concatenated or channelized SONET/SDH interfaces from OC3/STM-1 through OC48/STM-16.

In addition to the ports on the main board, OptiCop 10G supports a plug-on daughter-board with an additional 20 SFP ports.

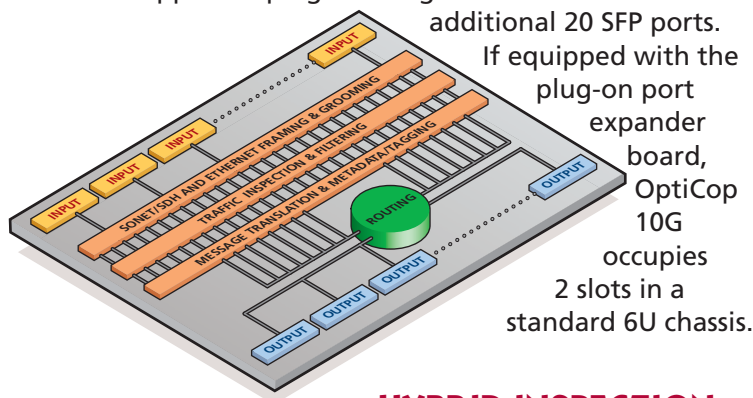

If equipped with the plug-on port expander board, OptiCop 10G occupies 2 slots in a standard 6U chassis.

HYBRID INSPECTION TECHNOLOGY

NetQuest has developed a powerful method to inspect traffic at line rate using its unique Hybrid Inspection Technology (HIT). HIT logic is based on highly parallel, pipelined hardware architecture with protocol specific inspection algorithms defined by software and executed in specialized hardware. The approach has been optimized to manage throughput delay and delay variations, ensuring monitoring and security equipment have an accurate view of network performance.

The OptiCop 10G leverages HIT technology by enabling the inspected data to be filtered and or routed based on user definable parameters. By filtering traffic, only the data of interest will be presented to the appliance for processing, ensuring its valuable processing resources are preserved.

For more detailed technical specifications, please email NetQuest at info@netquestcorp.com



TECHNICAL SPECIFICATIONS	
Size	Standard 6U cPCI
Power	15-45 W (110/220 VAC or 48 VDC)
Operating Temp	32° - 131° F (0° - 55° C)
Humidity	10-90% non-condensing
SFP Interfaces	Up to 4 Bi-Directional (plus an additional 20 Bi-Directional with a Port Expander Board)
XFP Interfaces	Up to 4 Bi-Directional
Mgmt. Interfaces	10/100 BT, EIA232 Craft
Mgtmt. Protocols	Telnet, SNMP V1-V3, GSCP

NetQuest Corporation • 523 Fellowship Road • Mount Laurel, NJ 08054 USA • +1.856.866.0505 • Fax: +1.856.866.2852 • Email: info@NetQuestCorp.com

NetQuest Corporation designs, manufactures and markets innovative monitoring access products for applications in telecommunications service provider, government, and enterprise networks. Founded in 1987 and based in Mount Laurel, New Jersey, NetQuest is privately held and operates under the original management team. With more than a 20 year track record of providing cutting edge monitoring access solutions, NetQuest has developed a global customer base, marketing directly and through a network of value added resellers and representatives.