

Blade Family - OptiCop 5

OVERVIEW

OptiCop 5 is a 6U cPCI module building block for system developers of network monitoring appliances. This universal high-speed networking module is designed for network access, monitoring, inspection, and surveillance applications in both WAN and LAN networks. OptiCop 5 incorporates a wide range of interfaces from copper T1/E1 to SONET/SDH to Ethernet. It may be used in stand-alone embedded single board appliances or as a blade in standard cPCI systems. High density, non-intrusive access guarantees predictable performance, keeping throughput and latency constant under any traffic load or user-defined filtering rule.

BENEFITS

- Non-intrusive access and optimization for monitoring applications
- Application support for IP, POS, ATM, and TDM networks including translations from Legacy to IP
- Protocol support for ATM, POS, Ethernet, IP Suite, HDLC, PPP, Frame Relay, SS7, and more.
- Access to Ethernet and SONET/SDH networks at rates of 155/622/1000Mbps
- Highly flexible system architecture powered by FPGA logic
- Accelerated time to market through easy integration into existing systems

SYSTEM INTEGRATION

OptiCop 5 can accelerate development time and expand the addressable market opportunities for system developers, enabling R&D resources to focus on application layer functionality. A single integration effort of the OptiCop 5 cPCI provides non-intrusive monitor connectivity to a wide variety of networks by utilizing reconfigurable FPGA technology to define the interface type of the universal SFP ports.

Management integration can be streamlined as well. OptiCop 5 can be managed by the appliance host controller using the management provisions defined

by PICMIG 2.0 standards or via NetQuest's proprietary UDP-based control protocol, GSCP.

APPLICATIONS

OptiCop 5 is suitable for applications in Performance Monitoring, Service Assurance, Revenue Assurance, Lawful Interception, Network Security, Test Equipment Access, and Forensics. The flexible technology allows for countless applications including:

- Inspection and interception of streams and messages on physical, link, and network layers and routing of selected traffic to one or more GigE or SONET/SDH outputs
- Switching, grooming, and broadcasting of SONET/SDH virtual tributaries down to T1/E1, and DS0/E0 streams
- Time-stamping, modifying, tagging, reformatting, and routing of GigE or SONET/SDH packets based on user criteria
- WAN/LAN protocol framing and header/payload analysis on concatenated or channelized (multi-channel) traffic streams.

continued...

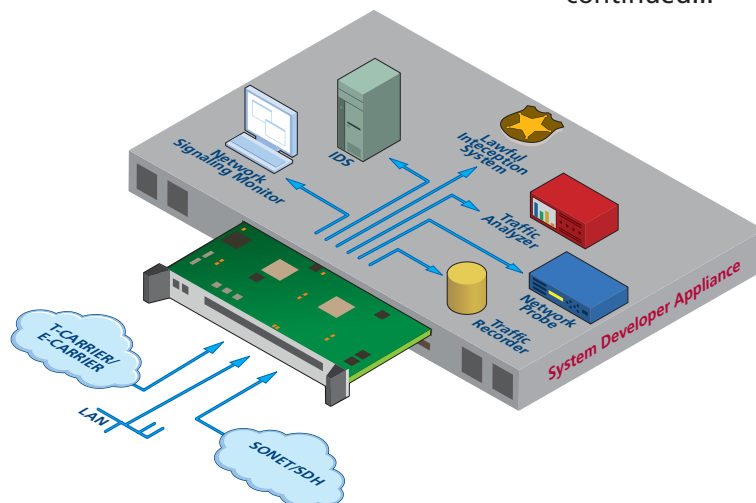

Integration of the OptiCop 5 into any cPCI-based appliance provides high-density multi-gigabit network access and optimization

- Monitoring and reporting of the WAN or LAN alarms and collection of traffic statistics on physical, link, network, and application layers
- Selective capture and forwarding of WAN or LAN traffic streams or packets

NETWORK PORTS

The OptiCop 5 is equipped with 1 dedicated 10/100/1000BaseT SFP data port and up to 4 universal SFP ports that function as monitor inputs or tool outputs. These ports are user definable to support Gigabit Ethernet and concatenated or channelized SONET/SDH interfaces for OC3/STM-1 or OC12/STM-4.

In addition to the 4 universal SFP WAN or LAN ports, OptiCop 5 supports one or two plug-on daughterboards for high density T1/E1 electrical interfaces. The T1/E1 boards are software definable for either T1 or E1 operation and support up to 128 physical interfaces

in cPCI environments. If equipped with two plug-on daughterboards, OptiCop 5 occupies 3 slots in a standard 6U chassis.

When OptiCop 5 is used in non-cPCI environments, daughterboards supporting up to 256 physical interfaces are also available.

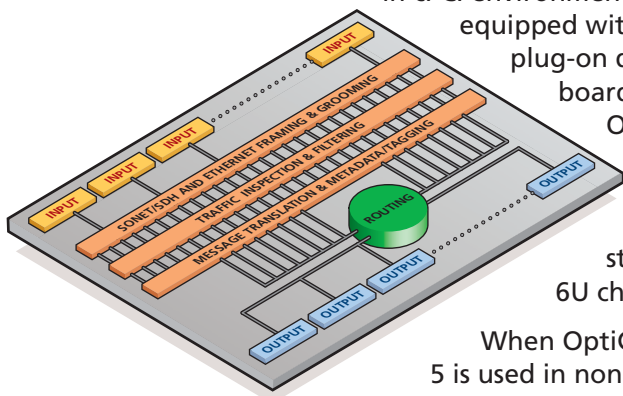

TECHNICAL SPECIFICATIONS	
Size	Standard 6U cPCI
Power	15-45 W (110/220 VAC or 48 VDC)
Operating Temp	32° - 131° F (0° - 55° C)
Humidity	10-90% non-condensing
SFP Interfaces	Up to 5 Bi-Directional
Mgmt. Interfaces	10/100 BT, EIA232 Craft
Mgmt. Protocols	Telnet, SNMP V1-V3, GSCP

For more detailed technical specifications, please email NetQuest at info@netquestcorp.com

NetQuest Corporation • 523 Fellowship Road • Mount Laurel, NJ 08054 USA • +1.856.866.0505 • Fax: +1.856.866.2852 • Email: info@NetQuestCorp.com

NetQuest Corporation designs, manufactures and markets innovative monitoring access products for applications in telecommunications service provider, government, and enterprise networks. Founded in 1987 and based in Mount Laurel, New Jersey, NetQuest is privately held and operates under the original management team. With more than a 20 year track record of providing cutting edge monitoring access solutions, NetQuest has developed a global customer base, marketing directly and through a network of value added resellers and representatives.