

## OptiCop Converger<sup>®</sup> : T-Series

### BENEFITS

- Broadband, Wideband, and Narrowband Grooming
- Interface conversions to leverage existing tools
- Multi-layer filtering to access only data of interest
- Remote monitoring and tool sharing to reduce CAPEX

### OVERVIEW

NetQuest's T-Series OptiCop Converger products provide test and monitoring access for today's high-speed SONET/SDH and T-Carrier/PDH networks in Telecom, Government, and Enterprise applications. The non-intrusive access optimizes tool port usage and enables network operators to implement management and assurance strategies related to the overall performance of the services being delivered, without degrading the service or distorting the results.

As transport networks continue to break speed barriers, SONET/SDH and T1/E1 circuits remain the only ubiquitous WAN standards around the globe. The OptiCop T-Series Convergers provide functionality similar to a Digital Cross-Connect System (DCS) at a fraction of the cost and use significantly less footprint. While SONET/SDH enables operators to flexibly and efficiently utilize network bandwidth by multiplexing services, each service needs to be measured independently relative to the expectations of the customer. OptiCop Converger and its Hybrid Inspection Technology (HIT) provide a means to extract the traffic of interest and leverage existing investment in test and monitoring tools.

### APPLICATIONS AND FEATURES

With OptiCop Converger deployed in a TDM network, engineers can groom and fill circuits to more effectively use the appropriate test and monitor tools. Everyday, network engineers are challenged with tool constraints like port and processing limitations, interface incompatibilities, protocol-specific testing, remote monitoring, and budget. Features like traffic aggregation, multicasting, load balancing, filtering,

and routing of IP and non-IP traffic make OptiCop Converger a powerful tool in the engineering of today's advanced networks.

By providing network interface conversions to GigE monitoring tools such as Sniffers, Performance Management Probes, Lawful Intercept Systems, Security/NAC Devices, Traffic Analyzers, and Bulk Data Recorders, OptiCop Converger provides real-time access to TDM network traffic. The TDM traffic can be translated into standard or proprietary Gigabit Ethernet, SONET/SDH, or T1/E1 traffic at full line rate without loss of data. OptiCop Converger's flexible interfaces, unique traffic handling capabilities, high port density, and powerful parallel processing functions set a new standard for monitoring access to converged IP networks.

### MONITORING ACCESS

The T-Series OptiCop Converger systems can be configured to meet the most demanding applications, with the ability to monitor SONET/SDH and T-Carrier/PDH circuits ranging from T1/E1 to OC-3/STM-1 through OC-48/STM-16. Broadband grooming (OC-n, STS-n, VC-4, and VC-3) comes standard with any T-Series system and can be optionally equipped with Wideband (VC-11 and VC-12) and Narrowband (64 Kbps timeslot) functionality. The T-Series OptiCop Converger can monitor multiple circuits in either half

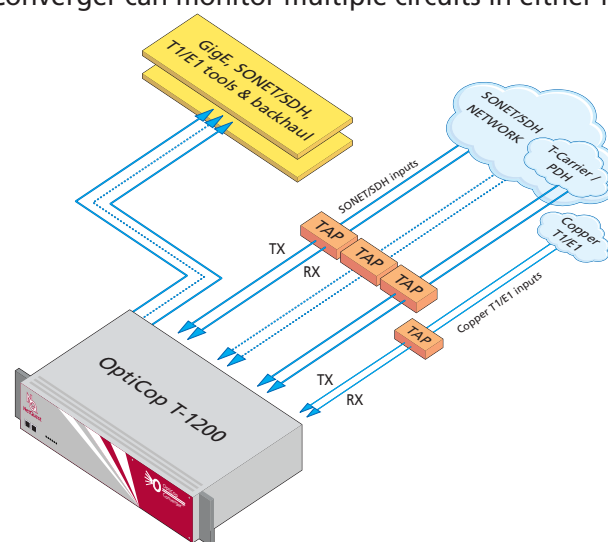

The T-1200 OptiCop Converger in SONET/SDH and copper T1/E1 networks

or full duplex scenarios and will operate in conjunction with Automatic Protection Switching, ensuring monitoring applications always have the access they need.

### HYBRID INSPECTION TECHNOLOGY (HIT)

NetQuest has developed a powerful method to inspect traffic at line rate using its unique Hybrid Inspection Technology (HIT). HIT logic is based on highly parallel, pipelined hardware architecture with protocol-specific inspection algorithms defined by software and executed in specialized hardware. HIT is equally effective in processing high-speed concatenated and channelized SONET/SDH and PDH circuits as it is in handling embedded low order SONET/SDH and PDH circuits.

### FILTERING AND ROUTING

The OptiCop Converger leverages HIT technology by enabling the inspected data to be filtered and or routed based on user definable parameters. By filtering traffic, only the data of interest will be presented to the monitor system for processing, ensuring valuable processing resources are preserved.

Routing of the data puts the user in control of which tool interface will receive the data, and enables network, protocol, and application partitioning to match monitoring system requirements and limitations.

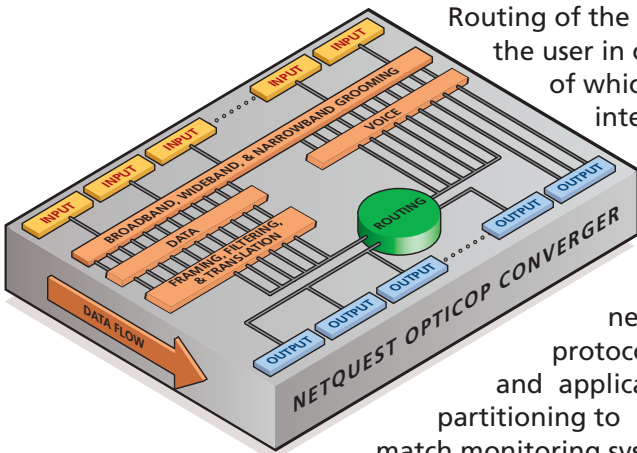

### CONFIGURATIONS

The T-Series OptiCop Converger is available in two models, the T-1200 and the T-2400, supporting 12 and 24 optical/copper interfaces respectively. Optional support for up to 256 discrete T1/E1 interfaces is

offered on the T-1200. Both models are available with either a fixed relationship between network inputs and tool outputs or with optional traffic routing, where the input to output relationship becomes a user defined logical path. The T-Series packaging is a 2RU chassis that is rack mountable and may be ordered with single or redundant power supplies with independent inputs for AC or DC sources. The table below illustrates example port configurations available. (Note: In certain input to output aggregation configurations, traffic inspection and filtering are required to prevent oversubscription)

|                                       | MODEL  |        |
|---------------------------------------|--------|--------|
|                                       | T-1200 | T-2400 |
| Total # SFPs (inputs + outputs)       | 12     | 24     |
| Max # OC3/STM-1 input ports           | 8      | 16     |
| Max # OC12/STM-4 input ports          | 8      | 16     |
| Max # OC48/STM-16 input ports         | 4      | 8      |
| Max # GigE output ports               | 8      | 16     |
| Max # T1/E1 copper input/output ports | 256    | -      |

### MANAGEMENT

The OptiCop Converger can be managed locally or remotely using menu-driven screens via Telnet or a serial crafts person port. Both interfaces provide secure access through a multi-level password protection system. OptiCop Converger has an integral SNMP V1-V3 agent that supports GET, SET, and TRAP functionality. NetQuest's proprietary UDP-based control protocol, GSCP, provides for integration of the OptiCop Converger interface into existing management systems.

For more detailed technical specifications, please email NetQuest at [info@netquestcorp.com](mailto:info@netquestcorp.com)

| TECHNICAL SPECIFICATIONS |  |
|--------------------------|--|
| Size                     | 2U rack mount or table top chassis:<br>3.5"H x 19"W x 17.25"D<br>(8.9cm H x 48.3cm W x 43.8cm D) |
| Weight                   | 16 pounds (7.27kg)   |
| Power                    | 140 W (110/220 VAC or 48 VDC)  |
| Operating Temp           | 32° - 122° F ( 0° - 50° C)   |
| Humidity                 | 10-90% non-condensing  |
| Compliance               | FCC, UL, CE, RoHS  |
| Management               | Telnet, EIA232 Craft, SNMP V1-V3   |

NetQuest Corporation • 523 Fellowship Road • Mount Laurel, NJ 08054 USA • +1.856.866.0505 • Fax: +1.856.866.2852 • Email: [info@NetQuestCorp.com](mailto:info@NetQuestCorp.com)

NetQuest Corporation designs, manufactures and markets innovative monitoring access products for applications in telecommunications service provider, government, and enterprise networks. Founded in 1987 and based in Mount Laurel, New Jersey, NetQuest is privately held and operates under the original management team. With more than a 20 year track record of providing cutting edge monitoring access solutions, NetQuest has developed a global customer base, marketing directly and through a network of value added resellers and representatives.